

Specifications

HD25VF - HD100VF

SPECIFICATIONS	HD25VF	HD30VF	HD45VF	HD60VF	HD100VF
Tilt: Load Torque in-lb (N.m)	31,875 (3602)	56,250 (6356)	84,375 (9534)	123,000 (13899)	205,000 (23165)
Rating Lbs.(kg) @ 6" (152mm) CG Height	2,500 (1134)	3,000 (1361)	4,500 (2041)	-	-
Rating Lbs.(kg) @ 12" (305mm) CG Height	1,700 (771)	3,000 (1361)	4,500 (2041)	6,000 (2721)	10,000 (4536)
Rating Lbs.(kg) @ 18" (457mm) CG Height	1,285 (583)	2,270 (1030)	3,400 (1542)	4,650 (2109)	7,700 (3493)
Rating Lbs.(kg) @ 24" (609mm) CG Height	1,035 (469)	1,830 (830)	2,750 (1247)	3,790 (1719)	6,300 (2858)
Rating Lbs.(kg) @ 30" (762mm) CG Height	875 (397)	1,530 (694)	2,300 (1043)	3,200 (1451)	5,300 (2404)
Rating Lbs.(kg) @ 36" (914mm) CG Height	750 (340)	1,300 (590)	1,975 (896)	2,750 (1247)	4,600 (2086)
Rating Lbs.(kg) @ 42" (1067mm) CG Height	650 (295)	1,100 (499)	1,720 (780)	2,400 (1089)	4,000 (1814)
Rating Lbs.(kg) @ 48" (1219mm) CG Height	580 (263)	1,000 (453)	1,530 (694)	2,200 (998)	3,600 (1633)
Rating Lbs.(kg) @ 54" (1371mm) CG Height	520 (236)	900 (408)	1,380 (626)	1,900 (862)	3,200 (1451)
Rating Lbs.(kg) @ 60" (1524mm) CG Height	470 (213)	830 (376)	1,250 (567)	1,700 (771)	3,000 (1361)
Rating Lbs.(kg) @ 66" (1676mm) CG Height	430 (195)	760 (345)	1,150 (522)	1,600 (726)	2,700 (1225)
Rating Lbs.(kg) @ 72" (1829mm) CG Height	400 (181)	700 (317)	1,100 (499)	1,500 (680)	2,500 (1134)
Rotation: Load Torque in-lb (N.m)	15,000 (1695)	36,000 (4068)	54,000 (6102)	72,000 (8136)	120,000 (13560)
Rating Lbs.(kg) @ 6" (152mm) Eccentric	2,500 (1134)	3,000 (1361)	4,500 (2041)	-	-
Rating Lbs.(kg) @ 12" (305mm) Eccentric	1,250 (567)	3,000 (1350)	4,500 (2041)	6,000 (2721)	10,000 (4536)
Tilt: 135° in how many seconds	23 Sec.	20 Sec.	20 Sec.	24 Sec.	49 Sec.
Tilt Motor Horse Power	1 HP	2 HP	3 HP	3 HP	3 HP
Rotation: Speed Range 50:1 AC Drive	2.0 - .040 rpm	1.2 - .024 rpm	1.2 - .024 rpm	1.5 - .030 rpm	1.0 - .020
Rotation Motor Horse Power	¼ HP	1 HP	1 ½ HP	3 HP	5 HP
Pendant cable length:	20 ft.	20 ft.	20 ft.	20 ft.	20 ft.
A: Table Size	30" x 30" (762x762mm)	36" x 36" (914x914mm)	36" x 36" (914x914mm)	48" x 48" (1219 x 1219mm)	48" x 48" (1219 x 1219mm)
B: Maximum Clamping Diameter	38-½" (978mm)	47" (1194mm)	47" (1194mm)	65" (1651mm)	65" (1651mm)
C: Number of slots and width	(4) 13/16" (20.6mm)	(4) 13/16" (20.6mm)	(4) 13/16" (20.6mm)	(4) 13/16" (20.6mm)	4) 13/16" (20.6mm)
Number of Table nuts and Thread	(4) ¾-10"	(4) ¾-10"	(4) ¾-10"	(4) ¾-10"	(4) ¾-10"
D: Pilot hole and depth	3.130"x½" (79.5 x 13mm)	3.130"x½" (79.5 x 13mm)	3.130"x½" (79.5 x 13mm)	3.130" x ½" (79.5 x 12.7mm)	3.130" x ½" (79.5 x 12.7mm)
E: Table Thickness	1-¼" (44.4mm)	1-¼" (44.4mm)	1-¼" (44.4mm)	2" (50.8mm)	2" (50.8mm)
F: Inherent Overhang	6-¾" (171.4mm)	6-¾" (171.4mm)	6-¾" (171.4mm)	8 1/2" (215.9mm)	8 1/2" (215.9mm)
Spindle OD Bearing Bore	2-1/2" (63.5mm)	2-1/2" (63.5mm)	3" (76.2mm)	3" (76.2mm)	4" (101.6mm)
Hollow Spindle Dia	None	None	None	None	None
Weld Current Conduction	1,500 Amps	1,500 Amps	2,000 Amps	2,000 Amps	2,000 Amps
G: Table flat, Minimum Height	34-½" (870mm)	34-½" (870mm)	34-½" (870mm)	44-½" (1130.3mm)	44-½" (1130.3mm)
Table flat, Maximum Height	56-½" (1435mm)	54-½" (1384.3mm)	54-½" (1384.3mm)	68-½" (1740mm)	74-½" (1892.3mm)
Adjustment Increments	5-½" (139.7mm)	5" (127mm)	5" (127mm)	6" (152.4mm)	6" (152.4mm)
H: Rotation axis, Minimum Height	27-¾" (704.8mm)	27-¾" (704.8mm)	27-¾" (704.8mm)	36" (914.4mm)	36" (914.4mm)
Rotation axis, Maximum Height	49-¾" (1263.6mm)	47-¾" (1212.8mm)	47-¾" (1212.8mm)	60" (1524mm)	66" (1676mm)
Matching TS	TS2	TS2	TS4	TS6	TS10
I: Tie down hole size	(6) 9/16" (14.3mm)	(6) 13/16" (20.6mm)	(6) 13/16" (20.6mm)	(6) 13/16" (20.6mm)	(6) 13/16" (20.6mm)
J: Front Mounting hole location	1-½" (38.1mm)	1-½" (38.1mm)	1-½" (38.1mm)	2" (50.8mm)	2" (50.8mm)
K: Center mounting hole location	19" (482.6mm)	23" (584.2mm)	23" (584.2mm)	30" (762mm)	30" (762mm)
L: Rear mounting hole location	19" (482.6mm)	20" (508mm)	20" (508mm)	24" (609.6mm)	24" (609.6mm)
M: Bolt hole pattern pitch	34" (863.6mm)	35-¾" (908mm)	35-¾" (908mm)	47-1/2" (1206.5mm)	47-5/8" (1209.7mm)
N: Overall base length	42-¼" (1073.1mm)	48" (1219.2mm)	48" (1219.2mm)	60" (1524mm)	60" (1524mm)
O: Overall Machine width	47" (1194mm)	48-¾" (1225mm)	48-3/8" (1229mm)	63-3/8" (1610mm)	61-13/16" (1570mm)
P: Overall machine length	50-¾" (1289mm)	60" (1524mm)	60" (1524mm)	76" (1930.4mm)	76" (1930.4mm)
Standard Primary Voltage	460/3/60	460/3/60	460/3/60	460/3/60	460/3/60
Shipping Weight	1500 lbs. (680kg)	1892 lbs. (858kg)	2080 lbs. (943kg)	3700 lbs. (1678kg)	4105 lbs. (1862kg)

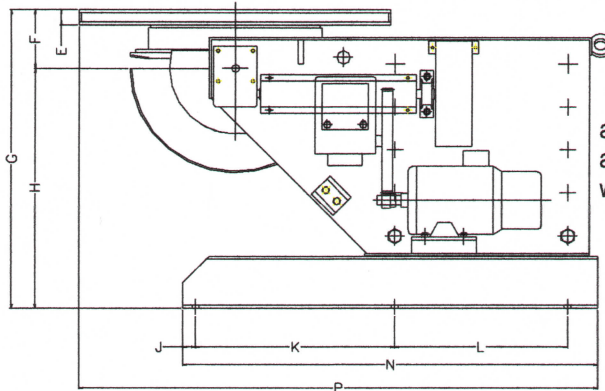
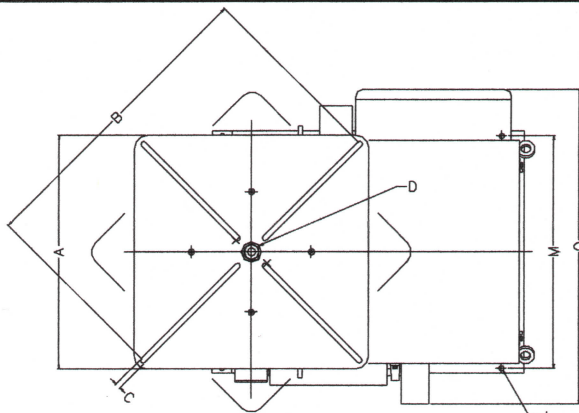

***All dimensions are for reference only and subject to change without notice.